

How strain gages work.

Strain, Stress, and Poisson's Ratio

When a material receives a tensile force P , it has a stress σ that corresponds to the applied force. In proportion to the stress, the cross-section contracts and the length elongates by ΔL from the length L the material had before receiving the tensile force (see upper illustration in Fig. 1).

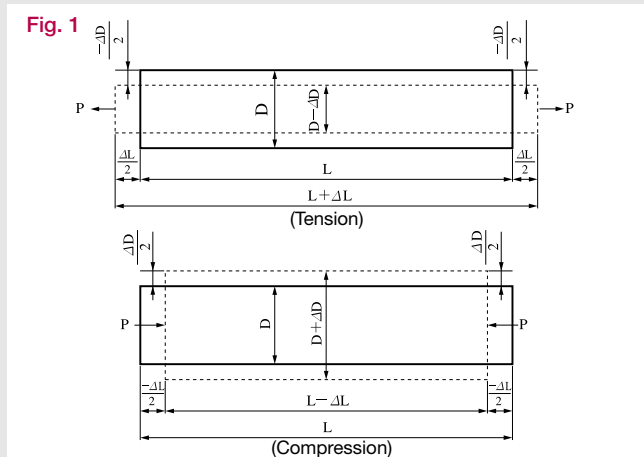

The ratio of the elongation to the original length is called a tensile strain and is expressed as follows:

$$\epsilon = \frac{\Delta L}{L}$$

ϵ : Strain
 L : Original length
 ΔL : Elongation

See the lower illustration in Fig. 1. If the material receives a compressive force, it bears a compressive strain expressed as follows:

$$\epsilon = \frac{-\Delta L}{L}$$

For example, if a tensile force makes a 100mm long material elongate by 0.01mm, the strain initiated in the material is as follow:

$$\epsilon = \frac{\Delta L}{L} = \frac{0.01}{100} = 0.0001 = 100 \times 10^{-6}$$

Thus, strain is an absolute number and is expressed with a numeric value plus $\times 10^{-6}$ strain, $\mu\epsilon$ or $\mu\text{m}/\text{m}$.

The relation between stress and the strain initiated in a material by an applied force is expressed as follows based on Hooke's law:

$$\sigma = E\epsilon$$

σ : Stress
 E : Elastic modulus
 ϵ : Strain

Stress is thus obtained by multiplying strain by the elastic modulus. When a material receives a tensile force, it elongates in the axial direction while contracting in the transverse direction. Elongation in the axial direction is called longitudinal strain and contraction in the transverse direction, transverse strain. The absolute value of the ratio between the longitudinal strain and transverse strain is called Poisson's ratio, which is expressed as follows:

$$\nu = \left| \frac{\epsilon_2}{\epsilon_1} \right|$$

ν : Poisson's ratio

ϵ_1 : Longitudinal strain $\frac{\Delta L}{L}$ or $-\frac{\Delta L}{L}$ (Fig. 1)

ϵ_2 : Transverse strain $-\frac{\Delta D}{D}$ or $\frac{\Delta D}{D}$ (Fig. 1)

Poisson's ratio differs depending on the material. For reference, major industrial materials have the following mechanical properties including Poisson's ratio.

Mechanical Properties of Industrial Materials

$$G = \frac{E}{2(1+\nu)}$$

Material	Young's Modulus E (GPa)	Shearing Modulus G (GPa)	Tensile Strength (MPa)	Poisson's Ratio ν
Carbon steel (C0.1 - 0.25%)	205	78	363 - 441	0.28 - 0.3
Carbon steel (C > 0.25%)	206	79	417 - 569	0.28 - 0.3
Spring steel (quenched)	206 - 211	79 - 81	588 - 1667	0.28 - 0.3
Nickel steel	205	78	549 - 657	0.28 - 0.3
Cast iron	98	40	118 - 235	0.2 - 0.29
Brass (casting)	78	29	147	0.34
Phosphor bronze	118	43	431	0.38
Aluminum	73	27	186 - 500	0.34
Concrete	20 - 29	9 - 13	—	0.1

Principle of Strain Gages

Each metal has its specific resistance. An external tensile force (compressive force) increases (decreases) the resistance by elongating (contracting) it. Suppose the original resistance is R and a strain-initiated change in resistance is ΔR . Then, the following relation is concluded:

$$\frac{\Delta R}{R} = K_s \frac{\Delta L}{L} = K_s \epsilon$$

where, K_s is a gage factor, the coefficient expressing strain gage sensitivity. General-purpose strain gages use copper-nickel or nickel-chrome alloy for the resistive element, and the gage factor provided by these alloys is approximately 2.

Types of Strain Gages

Types of strain gages include foil strain gage, wire strain gage and semiconductor strain gage.

Structure of Foil Strain Gage

The foil strain gage has metal foil photo-etched in a grid pattern on the electric insulator of the thin resin and gage leads attached, as shown in Fig. 2 below.

Fig. 2

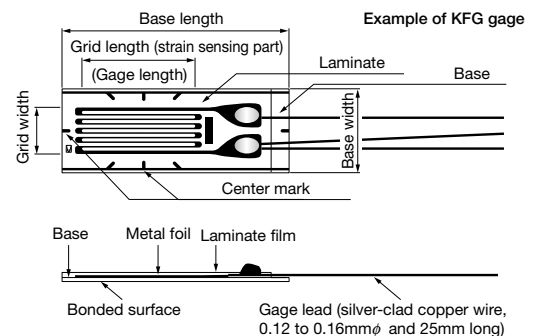

The strain gage is bonded to the measuring object with a dedicated adhesive. Strain occurring on the measuring site is transferred to the strain sensing element via the gage base. For accurate measurement, the strain gage and adhesive should match the measuring material and operating conditions including temperature. For the method of bonding the strain gage to metal, refer to Page 8.

Principle of Strain Measurement

Strain-initiated resistance change is extremely small. Thus, for strain measurement a Wheatstone bridge is formed to convert the resistance change to a voltage change. Suppose in Fig. 3 resistances (Ω) are R_1 , R_2 , R_3 and R_4 and the bridge voltage (V) is E . Then, the output voltage e_o (V) is obtained with the following equation:

$$e_o = \frac{R_1 R_3 - R_2 R_4}{(R_1 + R_2)(R_3 + R_4)} \cdot E$$

Suppose the resistance R_1 is a strain gage and it changes by ΔR due to strain. Then, the output voltage is,

$$e_o = \frac{(R_1 + \Delta R)R_3 - R_2 R_4}{(R_1 + \Delta R + R_2)(R_3 + R_4)} \cdot E$$

If $R_1 = R_2 = R_3 = R_4 = R$,

$$e_o = \frac{R^2 + R \Delta R - R^2}{(2R + \Delta R) 2R} \cdot E$$

Since R may be regarded extremely larger than ΔR ,

$$e_o \approx \frac{1}{4} \cdot \frac{\Delta R}{R} \cdot E = \frac{1}{4} \cdot K_s \cdot \epsilon \cdot E$$

Thus obtained is an output voltage that is proportional to a change in resistance, i.e. a change in strain. This microscopic output voltage is amplified for analog recording or digital indication of the strain.

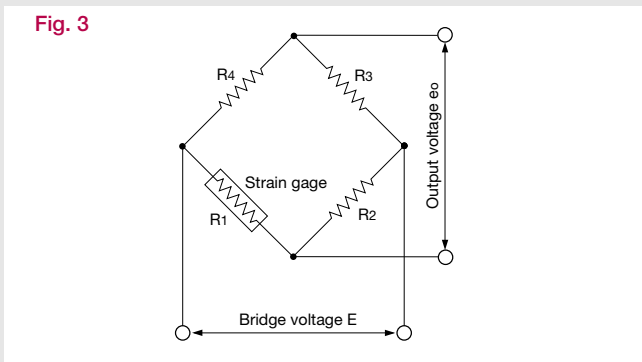

Strain-gage Wiring Systems

A strain-gage Wheatstone bridge is configured with 1, 2 or 4 gages according to the measuring purpose. The typical wiring systems are shown in Figs. 4, 5 and 6. For varied strain-gage bridge formation systems, refer to Bridge.pdf.

1-gage system

With the 1-gage system, a strain gage is connected to a side of the bridge and a fixed resistor is inserted into each of the other 3 sides. This system can easily be configured, and thus it is widely used for general stress/strain measurement. The 1-gage 2-wire system shown in Fig. 4-1 receives much influence of leads. Therefore, if large temperature changes are anticipated or if the leadwire length is long, the 1-gage 3-wire system shown in Fig. 4-2 must be used. For the 1-gage 3-wire system, refer to "Method of Compensating Temperature Effect of Leadwire" (Page 5).

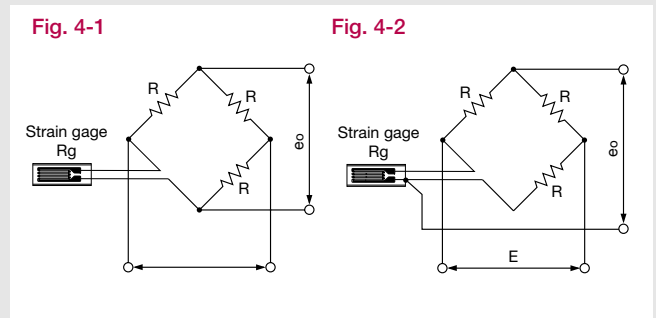

2-gage system

With the 2-gage system, 2 strain gages are connected to the bridge, one each to the 2 sides or both to 1 side; a fixed resistor is inserted into each of the other 2 or 3 sides. See Figs. 5-1 and 5-2 below. There exist the active-dummy method, where one strain gage serves as a dummy gage for temperature compensation, and the active-active method, where both gages serve as active gages. The 2-gage system is used to eliminate strain components other than the target strain; according to the measuring purpose, 2 gages are connected to the bridge in different ways. For details, refer to "How to Form Strain-gage Bridges" (Bridge.pdf).

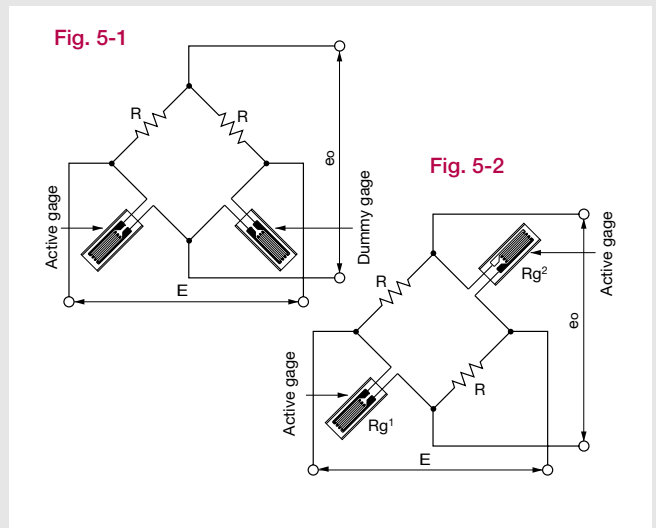

4-gage system

See Fig. 6. The 4-gage system has 4 strain gages connected one each to all 4 sides of the bridge. This circuit ensures large output of strain-gage transducers and improves temperature compensation as well as eliminates strain components other than the target strain. For details, refer to "How to Form Strain-gage Bridges" (Bridge.pdf).

Fig. 6

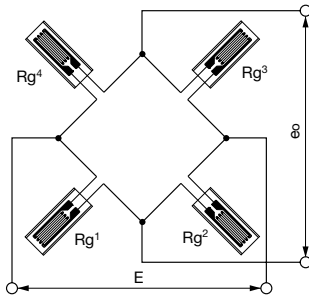

● Typical Measurements with Strain Gages

■ Bending Stress Measurement

(1) 1-gage System

As illustrated below, bond a strain gage on the top surface of a cantilever with a rectangular section. If load W is applied to the unfixed end of the cantilever, the strain-gage bonding site has the following surface stress σ :

$$\sigma = \epsilon_0 \cdot E$$

Strain ϵ_0 is obtained through the following equation:

$$\epsilon_0 = \frac{6WL}{Ebh^2}$$

where, b: Width of cantilever
 h: Thickness of cantilever
 L: Distance from the load point to the center of strain gage

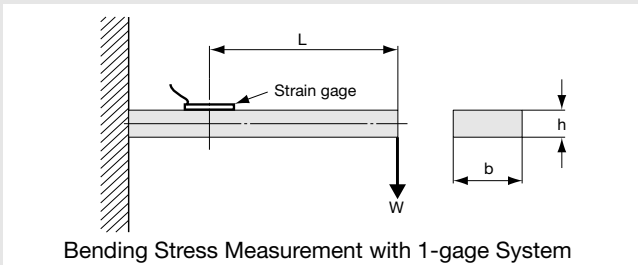

Bending Stress Measurement with 1-gage System

(2) 2-gage System

Strain gages bonded symmetrically on the front and rear surfaces of the cantilever as illustrated below output plus and minus signals, respectively, with an equal absolute value. If these 2 gages are connected to adjacent sides of the bridge, the output of the bridge corresponding to the bending strain is doubled and the surface stress σ at the strain-gage bonding site is obtained through the following equation:

$$\sigma = \frac{\epsilon_0}{2} \cdot E$$

The 2-gage system discards strain-gage output corresponding to the force applied in the axial direction of the cantilever.

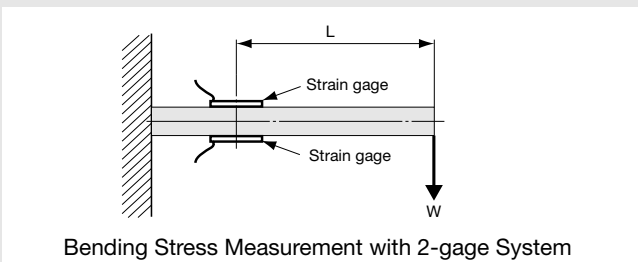

Bending Stress Measurement with 2-gage System

■ Equation to Obtain Strain on Beams

Strain ϵ_0 on beams is obtained through the following equation:

$$\epsilon_0 = \frac{M}{ZE}$$

where, M: Bending moment (refer to Table 1)
 Z: Section modulus (refer to Table 2)
 E: Young's modulus (refer to "Mechanical Properties of Industrial Materials," page 6)

Typical shapes of beams and their bending moments M and section moduli Z are shown in Tables 1 and 2.

Table 1. Typical Equations to Obtain Bending Moment

Shape of Beam	Bending Moment M
	$M = WL$
	$0 \leq L \leq \frac{l}{2} \rightarrow M = \frac{Wl}{2} \left(\frac{1}{4} - \frac{L}{l} \right)$ $L = 0L = \frac{l}{2} \rightarrow M = \pm \frac{Wl}{8}$ $\frac{l}{2} \leq L \leq l \rightarrow M = \frac{Wl}{2} \left(\frac{L}{l} - \frac{3}{4} \right)$
	$0 \leq L \leq \frac{l}{2} \rightarrow M = \frac{WL}{2}$ $L = \frac{l}{2} \rightarrow M = -\frac{WL}{4}$ $\frac{l}{2} \leq L \leq l \rightarrow M = \frac{W(l-L)}{2}$
	$0 \leq L \leq l_1 \rightarrow M = WL$ $l_1 \leq L \leq (l_1 + l_2) \rightarrow M = Wl_1$

Table 2. Typical Equations to Obtain Section Modulus

Cross Section	Section Modulus Z
	$\frac{1}{6} bh^2$
	$\frac{1}{6} \cdot \frac{b(h_2^3 - h_1^3)}{h^2}$
	$\frac{\pi}{32} d^3$
	$\frac{\pi}{32} \cdot \frac{d_2^4 - d_1^4}{d_2}$

Torsional and Shearing Stress Measurement of Axis

When twisted, an axis has shearing stress τ , and in the 2 directions inclined by 45° from the axial line it has tensile and compressive stress in an equal magnitude to the shearing stress.

In measuring strain on a twisted axis under simple shearing stress status, the strain gage does not directly measure the shearing strain but detects tensile or compressive strain initiated by tensile or compressive stress that is simultaneously generated with the shearing stress. Stress conditions on a microscopic part of the surface of the axis may be as illustrated below.

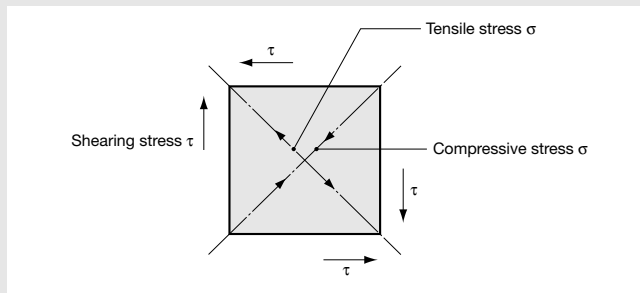

Shearing stress γ is defined as illustrated below, and the magnitude is calculated through the following equation:

$$\gamma = \frac{\tau}{G}$$

where, G: Shearing modulus (refer to "Mechanical Properties of Industrial Materials," page 1)
 τ : Shearing stress

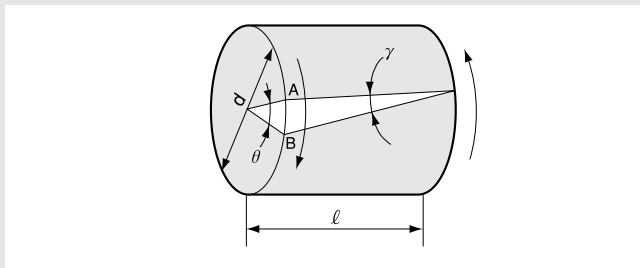

When the axis is twisted, point A moves to point B, thereby initiating torsional angle θ .

$$\theta = \frac{\ell \gamma}{\left(\frac{d}{2}\right)} = \frac{2 \ell \gamma}{d}$$

(1) Stress Measurement with 1-gage System

Bond the strain gage on the twisted axis in the direction inclined by 45° from the axial line. The relation between strain ϵ_0 and stress σ is expressed with the following equation to obtain tensile or compressive stress σ :

$$\sigma = \frac{\epsilon_0 \cdot E}{1 + \nu}$$

where, ϵ_0 : Indicated strain
 E: Young's modulus (refer to "Mechanical Properties of Industrial Materials," page 1)
 ν : Poisson's ratio

Stress σ and shearing stress τ are equal in magnitude, and thus,

$$\tau = \sigma$$

(2) Stress Measurement with 2 or 4-gage System

2 or 4 strain gages forming the strain-gage bridge are strained in an equal magnitude to enable 2 or 4 times larger output. Accordingly, the stress is calculated by dividing the indicated strain by 2 or 4.

For axial strain measurement, the 2 or 4-gage system is used to eliminate strain caused by bending moment. Also, for measurement of tensile strain and compressive strain, strain gages are symmetrically positioned from the center of the axis as shown below.

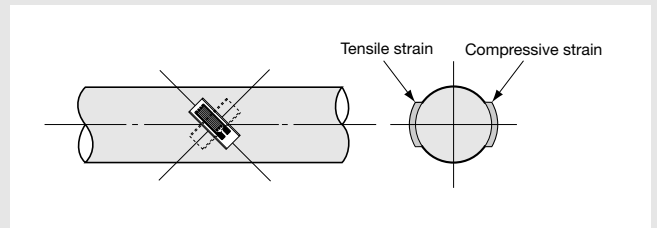

(3) Application to Torque Measurement

Strain on the surface of the axis is proportional to the torque applied to the axis. Thus, the torque is obtained by detecting the strain on the surface.

Shearing stress distributed on the lateral section is balanced with the applied torque T, establishing the following equation:

$$T = \tau \cdot Z_p$$

where, Z_p : Polar modulus of section

This equation may be rewritten as follows by substituting the shearing stress with the relational expression of tensile strain and stress:

$$T = \frac{\epsilon_0 \cdot E \cdot Z_p}{1 + \nu}$$

The polar modulus of the section is specific to each shape of the cross-section as follows:

Cross Section	Polar Modulus of Section Z_p
	$\frac{\pi d^3}{16}$
	$\frac{\pi}{16} \left(\frac{d_2^4 - d_1^4}{d_2} \right)$

A strain-gage torque transducer can be designed using the aforementioned relational expression of ϵ_0 and T.

Obtain ϵ_0 from the allowable stress for the material, and determine the width d of the axis which is matched with the magnitude of the applied torque. Then, amplify the strain output with a strain amplifier and read the output voltage with a measuring instrument.

● Principle of Self-temperature-compensation Gages (SELCOM® Gages)

Suppose the measuring object and the resistive element of the strain gage have linear expansion coefficients β_s and β_g , respectively. Then, the strain gage bonded on the surface of the object provides a thermally-induced apparent strain ϵ_T per 1°C that is expressed with the following equation:

$$\epsilon_T = \frac{\alpha}{K_s} + (\beta_s - \beta_g)$$

where,

- α : Resistive temperature coefficient of resistive element
- Ks: Gage factor of strain gage

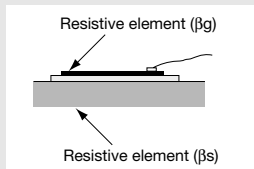

The self-temperature-compensation gage is designed so that ϵ_T in the above equation is approximated to zero by controlling the resistive temperature coefficient of the gage's resistive element according to the linear expansion coefficient of the measuring object.

When bonded to a suitable material, KYOWA's self-temperature-compensation gage (SELCOM® gage) minimizes apparent strain in the compensated temperature range to $\pm 1.8 \mu\epsilon/^\circ\text{C}$ (graph below shows apparent strain output of 3-wire strain gage).

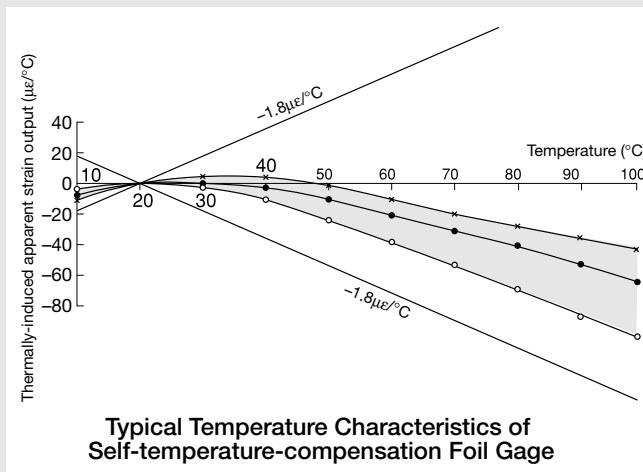

● Linear Expansion Coefficients of Materials ($\times 10^{-6}/^\circ\text{C}$)

Material	Linear Exp. Coef.	Material	Linear Exp. Coef.
Quartz glass	0.4	Beryllium	11.5
Amber	1.1	Common steel	11.7
Brick	3.0 to 5.0	Inconel X	12.1
Tungsten	4.5	Nickel	13.3
Lumber (grain dir.)	5.0	Gold	14.0
Molybdenum	5.2	SUS 304	16.2
Zirconium	5.4	Beryllium copper	16.7
Cobar	5.9	Copper	16.7
Concrete	6.8 to 12.7	Brass	21.0
Titanium alloy	8.5	2024-T4 aluminum	23.2
Platinum	8.9	2014-T4 aluminum	23.4
Soda-lime glass	9.2	Magnesium alloy	27.0
SUS 631	10.3	Lead	29.0
SUS 630	10.6	Acrylic resin	Approx. 65 to 100
Cast iron	10.8	Polycarbonate	66.6
NiCrMo steel	11.3	Rubber	Approx. 77

● Temperature Effect of Leadwire with 2-wire System

Leadwire Model	Cross-Sectional Area of Conductor (mm ²)	Reciprocating Resistance of 10m long Leadwire approx. (Ω)	Apparent Strain* with 10m Extension approx. (μϵ/°C)
L-5	0.5	0.7	11.3
L-9	0.11	3.2	50.6
L-6	0.08	4.4	69.0

*120Ω gage

Thermally-induced apparent strain ϵ_r ($\mu\epsilon/^\circ\text{C}$) is obtained through the following equation.

$$\epsilon_r = \frac{r_\ell}{R_g + r_\ell} \cdot \frac{\alpha}{K_s}$$

- where, R_g : Resistance of strain gage (Ω)
- r_ℓ : Resistance of leadwire (Ω)
- K_s : Preset gage factor of strain amplifier, usually 2.00
- α : Resistive temperature coefficient of copper wire ($\Delta R/R/^\circ\text{C}$), 3.9×10^{-3}

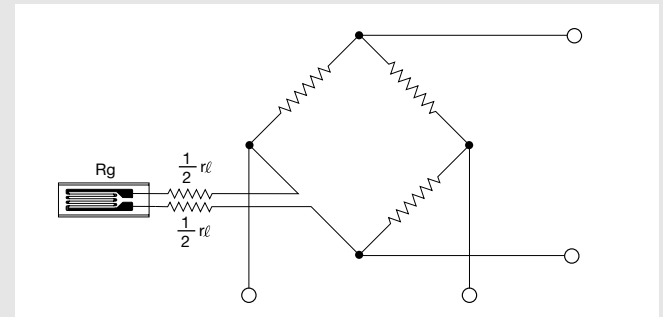

● Method of Compensating Temperature Effect of Leadwire (3-wire System)

For effective self-temperature-compensation, SELCOM® gages adopt the 1-gage system. However, if the leadwire cable is a 2-wire system, strain output from the bridge is affected by temperature effect of the leadwire. To avoid such adverse effect, the 3-wire system is adopted.

If 3 leads are connected to the strain gage as shown below, one half the leadwire resistance is applied to the adjacent side of the bridge to compensate the resistive components of the 2 leads affected by a similar temperature change, and thus the bridge output is free from any temperature effect of the leadwire. The temperature effect of a third lead connected directly to the amplifier can be ignored since the amplifier provides a high input impedance.

As precautions in using the 3-wire system, the 3 leads should be the same in type, length and cross-section to receive the same temperature effect. If they are exposed to direct sunlight, the coating color too should be identical.

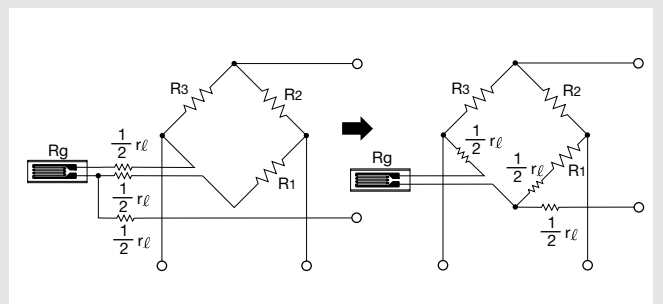

● Influence of Insulation Resistance

The insulation resistance of a strain gage including leads does not affect the measured value if it is higher than 100MΩ. But if the insulation resistance changes drastically during measurement, it causes the measured value to include an error.

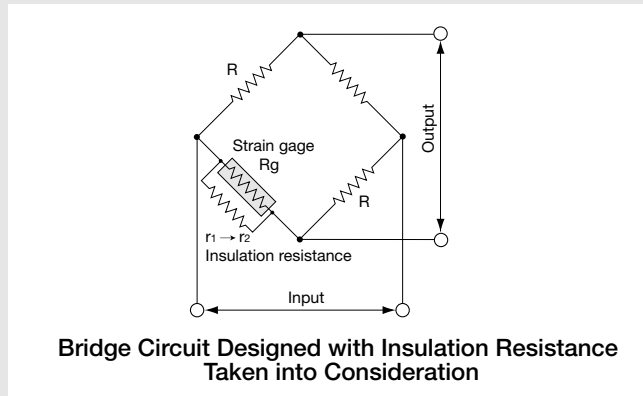

If the insulation resistance descends from r_1 to r_2 in the figure above, error strain ϵ is:

$$\epsilon \doteq \frac{R_g(r_1 - r_2)}{K_s r_1 r_2}$$

Suppose,

- $R_g = 120\Omega$ (resistance of strain gage)
- $K_s = 2.00$ (gage factor of strain gage)
- $r_1 = 1000M\Omega$ (original insulation resistance)
- $r_2 = 10M\Omega$ (changed insulation resistance)

Then, the error strain is approximately $6\mu\epsilon$. In general strain measurement, such an error causes virtually no problem. In practice, however, the lowered insulation resistance, r_2 , is not kept constant but sharply changes due to temperature, humidity and other conditions. Thus, it is not possible to specify to which part of the circuit the insulation resistance r is applied. Accordingly, precautions should be taken.

● Resistance Change of Strain Gage Bonded to Curved Surface

The strain ϵ_c occurring on the resistive element of a strain gage bonded to a curved surface may be expressed with the following equation:

$$\epsilon_c = \frac{t}{2r + t}$$

where, t : Thickness of gage base plus adhesive layer
 r : Radius of gage bonding surface

For example, if a uniaxial KFG gage of which the gage base including the adhesive layer is 0.015mm thick, is bonded to a curved surface of 1.5r, the strain gage receives strain of approximately $5000\mu\epsilon$ under the mere bonding condition. If the gage factor K_s is 2.00,

$$\Delta R/R \doteq 10000\mu\epsilon$$

since $\Delta R/R = \epsilon \cdot K_s$.

If the gage resistance is 120Ω, it increases by approximately 1.2Ω. If the gage is bonded inside the curve, the resistance decreases.

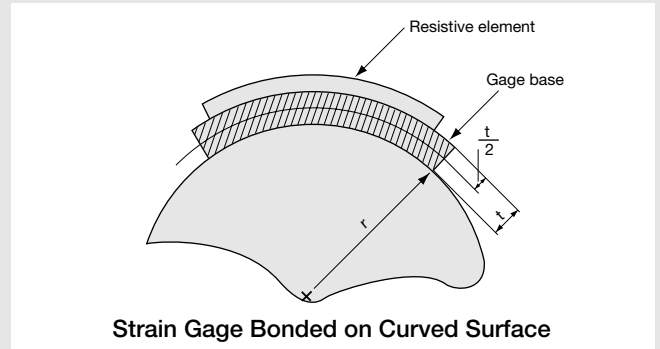

● Method of Compensating Gage Factors

If the gage factor of the strain gage is different from that (2.00) of the strain amplifier, the real strain ϵ can be obtained through the following equation:

$$\epsilon = \frac{2.00}{K_s} \times \epsilon_i$$

where, ϵ_i : Measured strain
 K_s : Gage factor of strain gage

● Misalignment Effect

The strain ϵ_0 measured by a strain gage that is misaligned by an angle θ from the direction of the principal strain is expressed with the following equation:

$$\epsilon_0 = \frac{1}{2} \{(\epsilon_1 + \epsilon_2) + (\epsilon_1 - \epsilon_2) \cos 2\theta\}$$

If $\epsilon_2 = -\nu\epsilon_1$ (ν : Poisson's ratio) under the uniaxial stress condition,

$$\epsilon_0 = \frac{1}{2} \epsilon_1 \{(1 - \nu) + (1 + \nu) \cos 2\theta\}$$

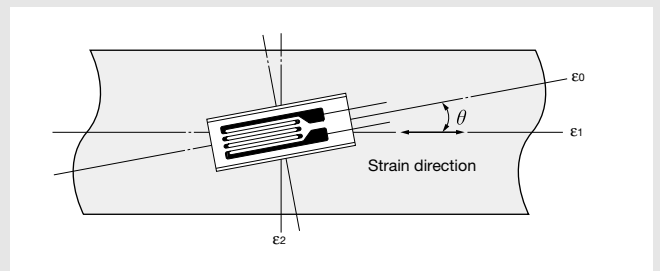

● Method of Compensating Leadwire Extension Effect

If the leadwire or cable is extended with the 1-gage or 2-gage system, additional resistance is initiated in series to the strain gage, thereby decreasing the apparent gage factor. For example, if a 10m long leadwire with 0.3mm² conductors is used, the gage factor decreases by 1%. In the case of the 4-gage system (transducer), the extension decreases the bridge voltage too. In these cases, the real strain ϵ can be obtained through the following equation (Supposing the gage factor K_s is 2.00):

$$\epsilon = \left(1 + \frac{r_l}{R_g}\right) \times \epsilon_i$$

where, ϵ_i : Measured strain
 R_g : Resistance of strain gage
 r_l : Total resistance of leadwire (For reciprocating resistance, see the table on the next page.)
 One-way resistance in the case of 3-wire system

Reciprocating Resistance of Leadwire

Cross-Section (mm ²)	Number/Diameter of Strands	Reciprocating Resistance per 10m (Ω)	Remarks
0.08	7/0.12	4.4	L-6, 7
0.11	10/0.12	3.2	L-9, 10
0.3	12/0.18	1.17	L-2
0.5	20/0.18	0.7	L-5

● Method of Compensating Nonlinearity of 1-gage System

Nonlinearity beyond the specification in large strain measurement with the 1-gage system can be compensated through the following equation to obtain the real strain ϵ :

$$\epsilon = \frac{\epsilon_0}{1 - \epsilon_0} \quad (\times 10^{-6})$$

where, ϵ_0 : Measured strain

● Method of Obtaining Magnitude and Direction of Principal Stress (Rosette Analysis)

Usually, if the direction of the principal stress is unknown in stress measurement of structures, a triaxial rosette gage is used and multiple physical quantities are obtained by putting measured strain values in the following equations. (These equations apply to right-angled triaxial rosette gages.)

Precautions in Analysis

- Regard $\epsilon_a \rightarrow \epsilon_b \rightarrow \epsilon_c$ as the forward direction.
- Angle θ is:
 Angle of the maximum strain to the ϵ_a axis when $\epsilon_a > \epsilon_c$;
 Angle of the minimum strain to the ϵ_a axis when $\epsilon_a < \epsilon_c$.
 Comparison between ϵ_a and ϵ_c in magnitude includes plus and minus signs.

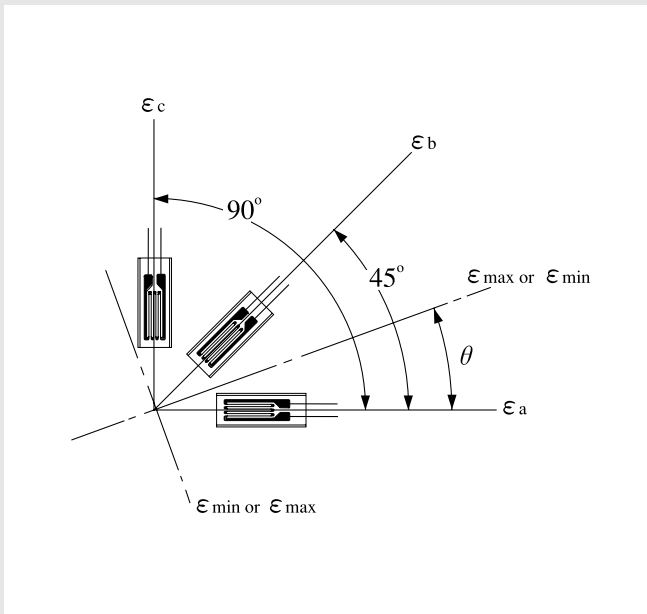

$$\text{Max. principal strain } \epsilon_{\max} = \frac{1}{2} \left[\epsilon_a + \epsilon_c + \sqrt{2\{(\epsilon_a - \epsilon_b)^2 + (\epsilon_b - \epsilon_c)^2\}} \right]$$

$$\text{Min. principal strain } \epsilon_{\min} = \frac{1}{2} \left[\epsilon_a + \epsilon_c - \sqrt{2\{(\epsilon_a - \epsilon_b)^2 + (\epsilon_b - \epsilon_c)^2\}} \right]$$

$$\text{Direction of principal strain (from } \epsilon_a \text{ axis)} \quad \theta = \frac{1}{2} \tan^{-1} \left[\frac{2\epsilon_b - \epsilon_a - \epsilon_c}{\epsilon_a - \epsilon_c} \right]$$

$$\text{Max. shearing strain } \gamma_{\max} = \sqrt{2\{(\epsilon_a - \epsilon_b)^2 + (\epsilon_b - \epsilon_c)^2\}}$$

$$\text{Max. principal stress } \sigma_{\max} = \frac{E}{2(1 - \nu^2)} \left[(1 + \nu)(\epsilon_a + \epsilon_c) + (1 - \nu) \times \sqrt{2\{(\epsilon_a - \epsilon_b)^2 + (\epsilon_b - \epsilon_c)^2\}} \right]$$

$$\text{Min. principal stress } \sigma_{\min} = \frac{E}{2(1 - \nu^2)} \left[(1 + \nu)(\epsilon_a + \epsilon_c) - (1 - \nu) \times \sqrt{2\{(\epsilon_a - \epsilon_b)^2 + (\epsilon_b - \epsilon_c)^2\}} \right]$$

$$\text{Max. shearing stress } \tau_{\max} = \frac{E}{2(1 + \nu)} \times \sqrt{2\{(\epsilon_a - \epsilon_b)^2 + (\epsilon_b - \epsilon_c)^2\}}$$

ν : Poisson's ratio

E : Young's modulus

(Refer to "Mechanical Properties of Industrial Materials" (page 6).

● Generating Calibration Value based on Tip Parallel Resistance Method

When extending the leadwire by several hundred meters or to obtain an accurate calibration value, use the tip parallel resistance method. The parallel resistance r can be obtained through the following equation:

$$r = \frac{R_g}{K_s \cdot \epsilon}$$

where, R_g : Resistance of strain gage
 K_s : Gage factor of strain gage
 ϵ : Calibration strain value

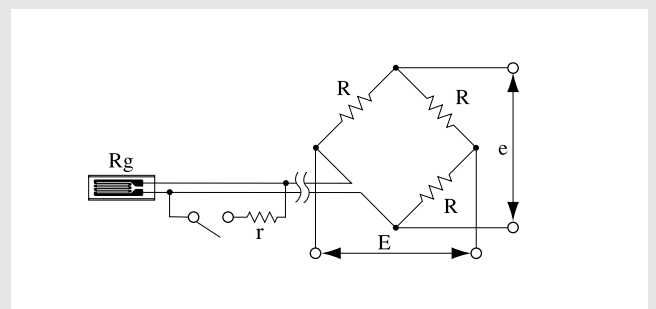

Examples of Calibration Strain Value and Resistance ($R_g = 120 \Omega$, $K_s = 2.00$)

Calibration Strain Value	Resistance, r (approx.)
100 $\mu\epsilon$	600 k Ω
200 $\mu\epsilon$	300 k Ω
500 $\mu\epsilon$	120 k Ω
1000 $\mu\epsilon$	60 k Ω
2000 $\mu\epsilon$	30 k Ω

Typical Strain Gage Bonding Method and Dampproofing Treatment

The strain gage bonding method differs depending on the type of adhesive applied. The description below applies to a case where the leadwire-equipped KFG gage is bonded to a mild steel test piece with a representative cyanoacrylate adhesive, CC-33A. The dampproofing treatment is in the case of using an butyl rubber coating agent, AK-22.

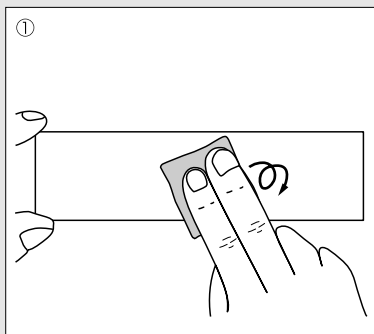

① Like drawing a circle with sandpaper (#300 or so), polish the strain gage bonding site in a considerably wider area than the strain gage size.

(If the measuring object is a practical structure, wipe off paint, rust and plating with a grinder or sand blast. Then, polish with sandpaper.)

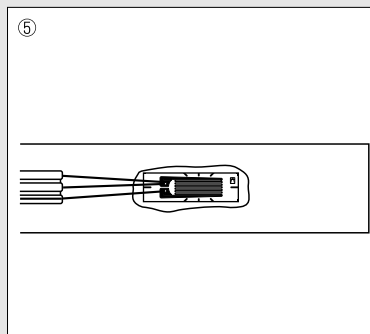

⑤ When the adhesive is cured, remove the polyethylene sheet and check the bonding condition. Ideally, the adhesive is slightly forced out from around the strain gage.

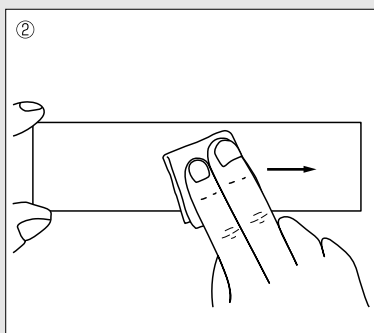

② Using an absorbent cotton, gauze or SILBON paper dipped in a highly volatile solvent such as acetone which dissolves oils and fats, strongly wipe the bonding site in a single direction to remove oils and fats. Reciprocated wiping does not clean the surface. After cleaning, mark the strain gage bonding position.

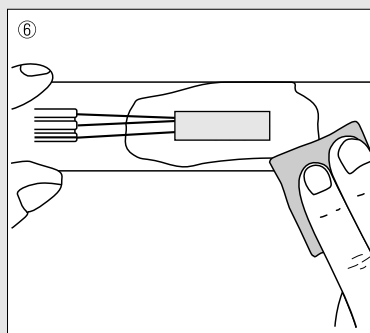

⑥ If the adhesive is widely forced out from around the gage base, remove the protruding adhesive with a cutter or sandpaper. Place gage leads in a slightly slackened condition.

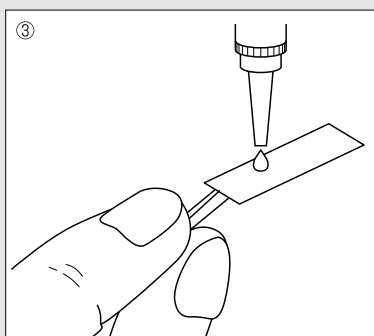

③ Make sure of the front (metal foil part) and the back of the strain gage. Apply a drop of adhesive to the back and immediately put the strain gage on the bonding site. (Do not spread the adhesive over the back. If so, curing is adversely accelerated.)

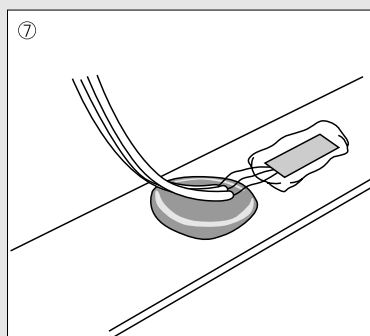

⑦ Put up the leadwire from before the part where the adhesive is applied. Place a block of the coating agent below the leadwire with gage leads slightly slackened.

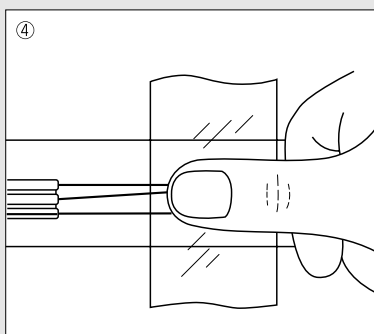

④ Cover the strain gage with the accessory polyethylene sheet and strongly press the sheet over the sheet with a thumb for approximately 1 minute (do not detach midway). Quickly perform steps 3 and 4. Otherwise, the adhesive is cured. Once the strain gage is put on the bonding site, do not put it up to adjust the position.

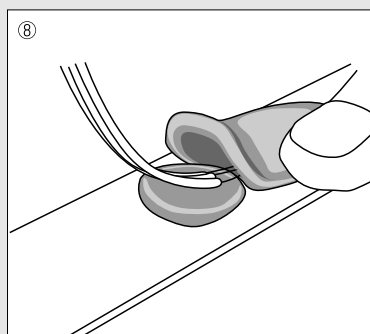

⑧ Completely cover the strain gage, protruding adhesive and part of the leadwire with another block of the coating agent. Do not tear the block to pieces but slightly flatten it with a finger to closely contact it with the strain gage and part of the leadwire. Completely hide protrusions including gage leads behind the coating agent.